

# 412

for residential swing gates  
with single leaf length of 1.8 m



■ **The ideal choice for residential gates**

The FAAC 412 is the most practical and economical choice for residential gates up to 1.8 metres in length per leaf. The 412 actuator is non-reversing and, therefore, does not require electric locks and bolts.

■ **Quick and easy to install**

Quick and easy to install, no need for expensive modifications to the existing load bearing structure. Use of electro-mechanical technology makes the FAAC 412 ideal for light duty applications.

■ **Electronic safety**

Anti-crushing protection is ensured by an electronic device installed on the FAAC control boards, which directly controlling operator drive torque. In case of an emergency, the release key makes it possible to operate the gate manually.

■ **Less maintenance, highly reliable**

The FAAC 412 electro-mechanical device cuts down considerably on maintenance. Reliability is assured under all atmospheric conditions and in an outdoor temperature range of -20°C to +55°C.



■ Emergency release



■ Electric motor complete with thermal protection

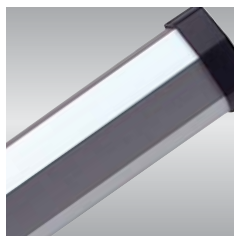

■ Rod protective housing



- 1 Rod protective housing
- 2 Emergency release
- 3 Electric motor complete with thermal protection



**DIMENSIONS**

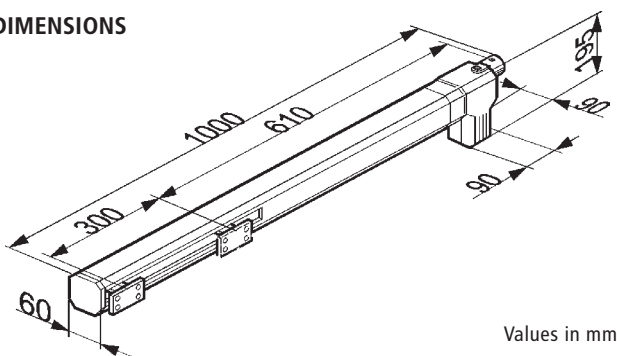

Values in mm

Technical specifications	412
Power supply	230 Vac (+6% -10%) 50 (60) Hz
Absorbed power	280 W
Absorbed current	1.5 A
Motor rotation speed	1.400 rpm
Rod extension speed	1.5 cm/s
Traction and thrust force	0 ÷ 320 daN
Thermal protection on motor winding	140°C
Operating ambient temperature	-20°C ÷ +55°C
Protection class	IP 44
Weight	6.5 kg

Model	Use	
	Single leaf max length (m)	Use frequency (cycles/hour)
412 RH	1,80	18
412 LH	1,80	18

NOTE: Right (RH) and left (LH) has to be considered from inside the property.

Electronic control equipment: see from page 124 to page 130.