

740 - 741

for residential sliding gates
with max weight of 500 kg (740) and 900 kg (741)



■ Cover

■ Rotating release device easy to operate and key "protected" (standard)

■ Automatic simplicity

A practical package, containing a gearmotor with built-in electronic equipment and securing plate, automates both new and existing sliding gates weighing up to 900 kg.

■ Ideal for residential applications

The electronic equipment inside the gearmotor facilitates and speeds up installation, at lower cost. Control board enclosure with "rotation" facility to help electrical wirings.

■ Electronic safety reliable under all conditions

Anti-crushing protection is ensured by an electronic device directly controlling drive torque. For extra safety, an efficient obstacle detector is available.

The FAAC 740/741 gearmotors perform uniformly at all latitudes and under all types of duty, and all commands are supplied by an extremely safe and reliable microprocessor.

■ Irreversible

As the gearmotor is non reversing, no electric locks need be installed and, in the event of power failure, the release device (protected by a customised key) makes it possible to open and close manually.



- 1 740 D control board
- 2 Plastic cover control board



DIMENSIONS

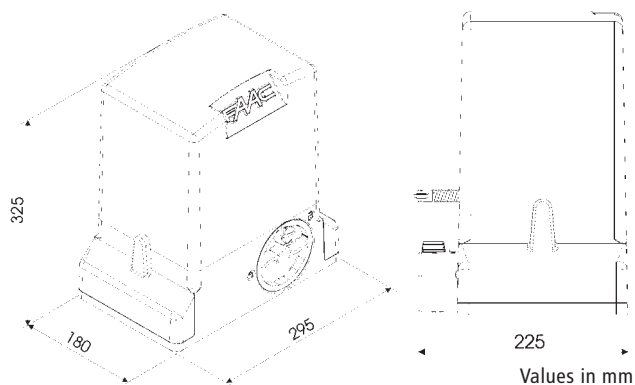

Technical specifications	740 E Z16	741 E Z16
Power supply	230 Vac 50 (60) Hz	
Absorbed power	350 W	500 W
Absorbed current	1,5 A	2,2 A
Traction and thrust force	45 daN	65 daN
Motor rotation speed	1400 rpm	
Thermal protection on motor winding	140°C	
Reduction ratio	1:25	
Weight	500 kg	900 kg
Gate speed	12 m/min (pinion Z16)	
Operating ambient temperature	-20°C ÷ +55°C	
Protection class	IP 44	
Dimensions	295x225x325 (pinion included)	

Specifications of 740 D control board

Power supply	230 Vac (+6% -10%) 50 Hz
Absorbed power	10 W
Motor maximum load	1000 W
Accessories max load	0.5 A
Operating ambient temperature	-20° C ÷ +55° C
Protection fuses	2
Function logics	Automatic / "Stepped" automatic/Semi-automatic / Safety devices / Semi-automatic B / Dead-man C / "Stepped" Semi-automatic
Work time	Programmable (from 0 to 4 min.)
Pause time	Programmable (from 0 to 4 min.)
Thrust force	Adjustable over 50 levels
Terminal board inputs	Open / Partially open / Opening safety devices / Closing safety devices / Stop / Edge / Power supply + Earth
On-connector inputs	Opening and closing limit-switches / Encoder (optional)
Terminal board outputs	Flashing lamp - Motor - 24 Vdc accessories power supply - 24 Vdc indicator-light / Timed output - Fail safe
Rapid connector	Connection for Minidec, Decoder or RP receivers
Programming	3 keys (+, -, F) and display, "basic" or "advanced" mode
"Basic" mode programmable functions	Function logic - Pause time - Thrust Force - Gate direction
"Advanced" mode programmable functions	Fail safe - Pre-flashing - Indicator-light/Timed output - Opening and closing safety devices logic - Encoder (optional) for anti-crushing electronic safety, deceleration management and partial opening - Decelerations - Partial opening time - Work time - Assistance request - Cycle counter

Model	Use		Control board
	Max weight (kg)	Use frequency (cycles/hour)	
740 E Z16	500	30 (S3)	740 D built-in
741 E Z16	900	40 (S3)	740 D built-in